

Towards Sustainable Productivity

A guide to reduce your environmental footprint



Sustainable Productivity

Atlas Copco

Putting sustainable productivity into practice

The cornerstones of our sustainable productivity goals are to help you work more efficiently and economically, more safely, in ways that minimize the impact on the environment. To reach our objectives, and help you benefit from our efforts, we constantly challenge ourselves to find new ways of working using a balance of the resources available to us – human, natural and capital.

We focus on whole life costs instead of short-term profitability. This makes it possible for you to maximize your return on investment when you choose Atlas Copco tools. We also optimize energy consumption at every stage of production in our ISO certified manufacturing facilities. Every tool and solution we introduce is engineered to be better for business, society and the world we all live and work in – for today and far into the future.

Saving energy is a leading priority

Finding new ways of reducing the amount of energy our tools use while increasing productivity is always top of mind. One powerful example of this is the CO₂ neutral tightening that's possible with our battery tools. Another is an air line audit that allows you to monitor the efficiency of the compressors in your air line facilities and how much pressure is actually delivered to the pneumatic tools being used. It's solutions such as these, and many more, that provide a world of new opportunities for improving and sustaining productivity over time.



Why quality is a good investment

Tools that are designed to operate at peak efficiency with the highest regards for health and safety are hallmarks of the Atlas Copco brand. To help you improve your productivity and sustain it over a longer work-life, we also strongly emphasize the benefits of preventative maintenance. As a result, the increases in uptime over many more years of use directly translate into lower operating costs.



Innovation that protects the environment

By implementing manufacturing processes that directly reduce CO₂ emissions in our own facilities, we're actively working to protect the natural environment. We also introduce products that allow people and companies who use our tools to benefit from the same positive impact. For instance, we always develop tools that use less power than previous models. Engineering tools to last longer is yet another. As a result of these innovations and many others, we help ensure a brighter future for future generations.



Ergonomic improvements that increase productivity

We're always looking for new ways of designing tools that have better power-to-weight ratios. The use of stronger, lighter materials such as carbon-fibre is one way we accomplish this. We also make sure the tools are properly aligned and balanced. This makes them easier to aim and more safe to work with over longer periods of time. And we incorporate solutions that dampen vibration. All of this works together to make it possible to increase your productivity – easily.

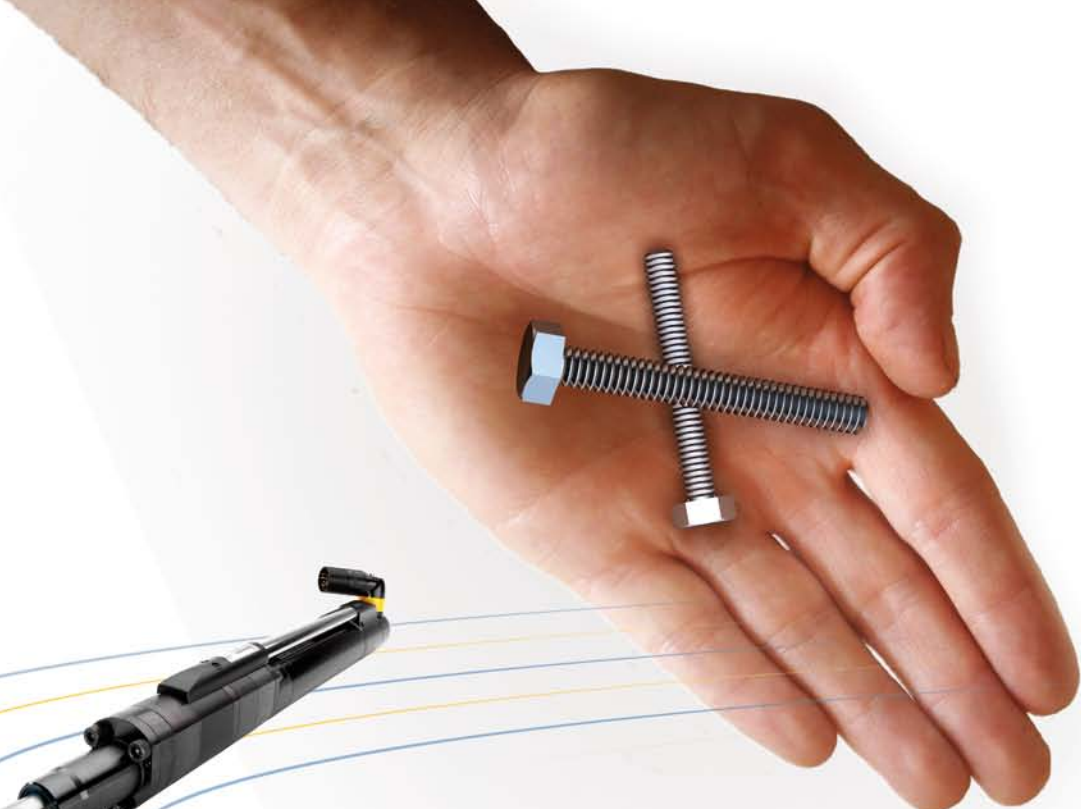

Let the technology work

With QST nutrunner you apply a yield control strategy that give optimal clamp force.

M8 → M6

Reduce weight

Switching to smaller bolts can reduce the weight of cars with up to 20 kilos per vehicle.

-20 kg



Save Fuel & Lower CO² Emissions

The lighter the vehicle, the less fuel that's needed to drive it – and less CO₂ emissions are released into the atmosphere.

-200 ltr



x5

Cut Transportation Costs

If every vehicle was manufactured using smaller bolts, it would cut fuel consumption by 12,000,000,000 liters a year, the equivalent of five oil tankers, and dramatically reduce CO₂ emissions on a global scale.

“What if we changed to a smaller bolt?”

Sometimes, the answer to a seemingly simple question can make an enormous difference.

For example, design engineers at a major truck manufacturer wondered what might result from using electric tools to assemble the chassis of their trucks and busses with smaller bolts – instead of the pneumatic tools and larger bolts that they were used to working with.

The results were incredibly eye-opening. They discovered that by migrating from pneumatic to electric tools – and smaller bolts and screws in the process – the weight of every chassis assembled could be reduced by up to 200 kilos.

The facts behind this story can be found in “The Weight Loss Method” – which is the result of the German VDI2230 standard. One of the secrets is the use of Atlas Copco electric tools.

Initially, large European truck and bus manufacturers began using electric tools because vibrations are minimized. Electric tools are also quieter. Quality can be monitored. And more precision and control are possible. However, in recent years, it’s the ability to save weight by using smaller bolts and screws that’s drawn more attention.

Carl Carlin, Head of “Advanced Fastening Technology” at Atlas Copco, believes this gives manufacturers big advantages. And by multiplying the effects of saving 200 kilos on every large truck or bus, it’s an area that can result in big savings for the environment as well. From the use of natural resources for manufacturing, to the costs of transporting vehicles, to the energy savings that result from operating lighter vehicles – the use of electric tools can make an enormous impact in a multitude of ways.



Reduce your environmental footprint

Atlas Copco offers several solutions that are ready to go to work on your production floor today. From specialty shops to large, high-volume global manufacturers, we have what

you need to reduce your environmental footprint in ways that will clearly show on your bottomline, while improving competitive edge and corporate social responsibility.



Migrate to electric tools

The greatest leap you can make in terms of energy efficiency is to migrate to sophisticated electrical tools with built-in intelligence. Imagine being able to deliver a perfect job, every time. As a bonus you also get traceability and constant feedback for the ultimate in quality control.



Optimize your air line

A huge amount of energy is wasted due to leaks in compressed air systems. Capacity losses of up to 15-20% are common in many installations. Atlas Copco offers everything you need to measure efficiency and increase output by up to 10%.



CO₂
EMISSIONS

ENERGY
COST

ENERGY
EFFICIENCY



Achieve CO₂ neutral tightening

With our new generation of smart battery-powered tools you can use renewable energy sources, such as solar or wind to recharge battery packs and power the communication system. In a properly engineered system you'll need no energy from the outside – your tightening becomes completely CO₂ free.



CO₂
EMISSIONS

ENERGY
COST

ENERGY
EFFICIENCY

Change to high performing air tools

Atlas Copco tools consistently outperform competitors in power relative to weight. Not only are our tools lighter; they're also often faster, as well. In all, you get shorter working times, less energy consumption and better ergonomics. That's a strong synergy – for your operators and your bottom line.

Improve the efficiency of your air line

There is a huge amount of energy wasted by leakages due to less than optimal installation. But, in fact, this can be prevented quite easily. For example, using high flow couplings attached to the correct size of hoses, and having the correct regulators in place, can result in significant energy cost savings and increased productivity.

Using just one bar more of pressure than what's needed unnecessarily increases air pressure by 16% - which directly translates into higher energy consumption and costs. Having the correct regulators alone can go a long way towards reaching peak efficiency and energy savings. In addition, good installation also improves overall productivity by allowing workers to accomplish more in fewer hours.



1 CO₂ TONNES -350
38% EFFICIENCY INCREASE

Compressor energy efficiency

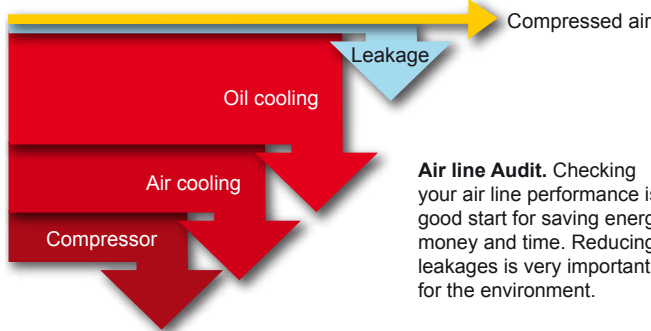

Air line Audit. Checking your air line performance is a good start for saving energy, money and time. Reducing leakages is very important for the environment.

Air line Accessories. High flow couplings, correct-sized air lines and regulators are key to achieving peak performance.



Put the most effective air tools to work for you

Greater speed is the beginning of a winning formula. For example, by choosing a nutrunner from Atlas Copco's LTV-series you may be able to increase speed by up to 50%. Naturally this dramatically shortens tightening cycles while also increasing productivity.

It's also interesting to evaluate how this greater speed impacts energy consumption. Since the tool performs twice the work with the same amount of power, it's easy to see the benefit – a given increase in speed is directly matched by an equal percentage of savings in energy.



1 CO₂ TONNES -30%
50% EFFICIENCY INCREASE

Speed is the key

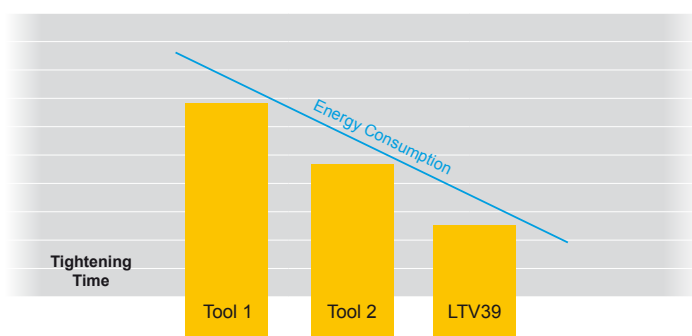

Migrate to electrical tools

Tools powered by compressed air have a lot of positive benefits to offer you – including proven durability and easy operation. However, they also consume up to 20 times more energy than their electrical counterparts. Which is why migrating to electric tools makes so much sense in both the short-term and the long run.

Electric tools are more comfortable to work with, they vibrate less and make less noise. In larger, advanced industrial production facilities, they also offer traceability and quality monitoring. All of this adds up to helping achieve sustainable productivity.



CO₂ EMISSIONS **-85%**
85% EFFICIENCY INCREASE

Tool cost and environmental impact

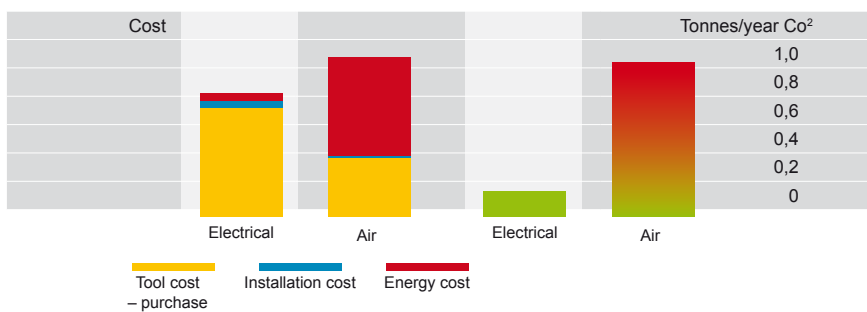

Making the transition from air to electric tools benefits both business and the environment.

CO₂ neutral tightening

The biggest impact on energy savings you can get is by powering your production line with solar panels or windmills. The evolution of tools from those that are powered by air and electricity, to ones that operate on batteries, makes this possible and translates into greater savings. By developing tools such as these, with renewable energy, the savings are immediately evident and lasting. In addition, these advanced tool solutions mean that sustainability can be put in place without sacrificing practicality or productivity. This is just one more leading example of how we are committed to making positive, long-lasting impacts on the industries who rely on our tools - every day.



CO₂ EMISSIONS **-100%**
85% EFFICIENCY INCREASE

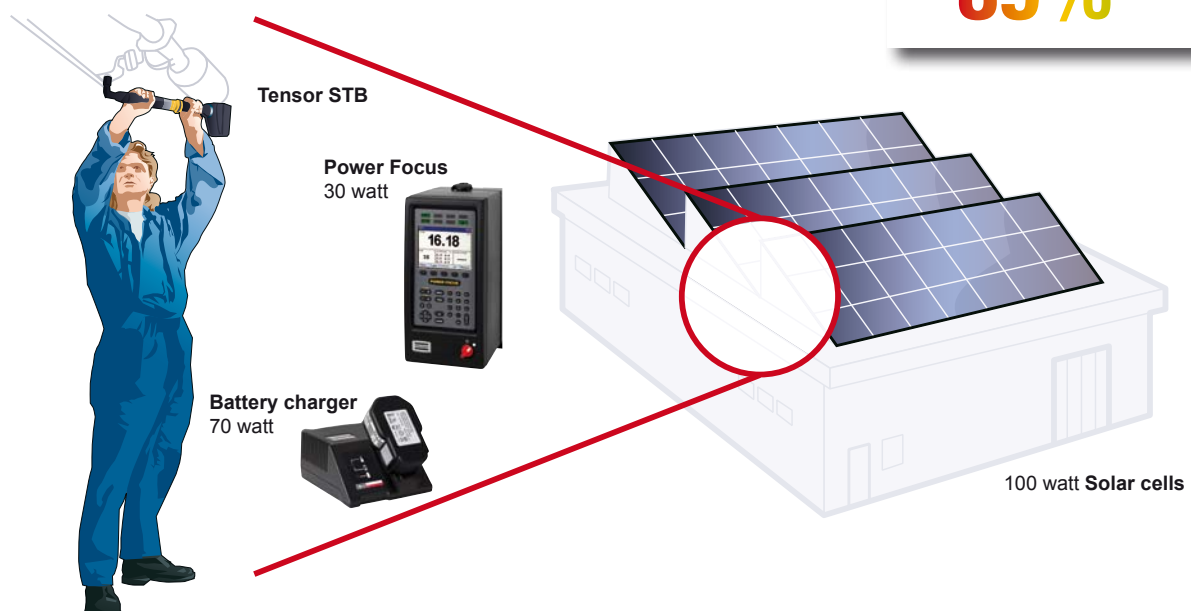

Good ergonomics means a better worklife

We believe that operators are the key to achieving higher quality and a sharper competitive edge. So we have always focused on developing tools that allow people to work complete days at a consistent level of high quality without giving up a rewarding personal life.

Good ergonomics are also important for maintaining a

healthy bottom line for businesses who manufacture goods. In workplaces where power tools are used, injuries may be common if safety standards are not in place – not to mention costly. Scientific reports indicate the costs for productivity losses and quality problems are at least three times higher than the disorder itself.

Make an ergonomics audit

To avoid unnecessary injuries and minimize operator fatigue, Atlas Copco helps you discover new areas for ergonomic improvement. In this audit, we study various

factors that typically contribute to known work disorders. We also look at related potential hazards and how to generally improve worker safety.

Perfectly balanced tools

Thanks to 50 years of focusing on ergonomics, Atlas Copco tools fit comfortably in your hand. Their perfect balance and comfortable fit increase productivity and make working conditions much safer in the long run.



Reduce vibrations

Vibrations from tools is by far the greatest threat for an operator's health. EU has published guidelines regulating exposure to vibration in the workplace. Read more in our pocket guide "Vibration Exposure Assessment for Industrial Power Tools".



Risk reducing accessories

Torque arms, reaction bars and other accessories can help prevent injury caused by prolonged use by reducing the weight of a tool for individual operators. And each accessory is engineered with an emphasis on safe, reliable operation.

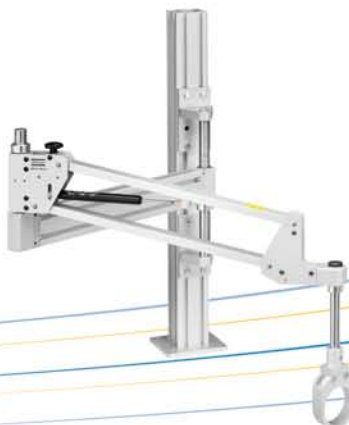

High power, low weight

The continuous journey to pack more power into lighter tools is a top priority. Within many segments of tools, we are recognized as the leader in power-to-weight.



Higher quality leads to better economy

One of the greatest threats to our society and the environment is over-consumption and the short-term perspective many people have for manufactured goods. Simply put, we have to stop throwing away things and make the most of our resources.

This is foremost in our minds when we design tools. We always consider how we can achieve the longest lifecycle. So each tool has to be of the highest quality possible. To achieve this, we constantly look at how we can refine details that also consider the bigger picture.

For example, by designing tools that use spiral angle gears with an improved contact area instead of conventional gears, the life of each tool is lengthened. As a result, compared to tools that are used for a short time, then have to be discarded for recycling, Atlas Copco tools are engineered for long life. Our tools are also manufactured to extremely tight tolerances so they operate more smoothly – often lubrication-free – over longer periods of time. And other innovations, such as the use of carbon

fiber instead of lightweight plastic, can add years to the durability of the tools.

There are many factors to consider when comparing the lifetime cost of Atlas Copco tools to tools that may have a lower initial purchase price – but lower quality as well. Among these considerations are:

- Higher quality
- Fewer recalls
- Stronger warranties
- Less rework
- Fewer injuries

It all starts by having the right tools for the job at hand. First, invest in better quality tools that will last. Then, make sure they last even longer by following a proper maintenance program. It's not just good business. More important, it's invaluable to put practices and tools in place that are better for the environment today, tomorrow and far into the future.

Service is a good investment

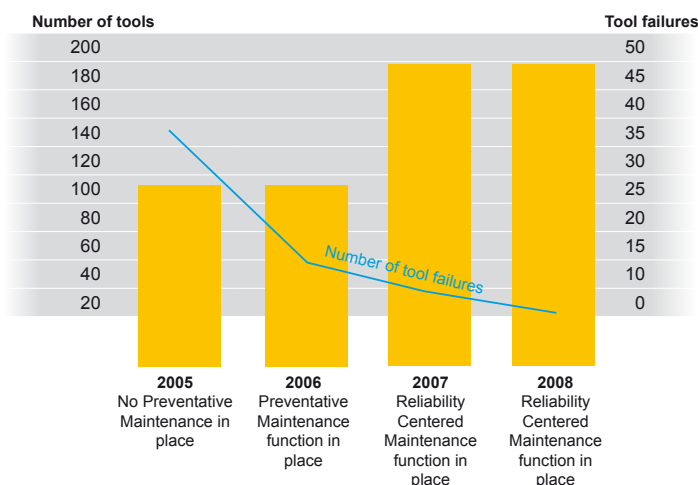

The figures presented above indicate how a factory that produces 110,000 engines annually has reduced tool failure by nearly 50% each year over a three-year period. These results were achieved by installing high-quality Atlas Copco tools, followed by both a preventive maintenance program, and a reliability-centered maintenance program.





www.atlascopco.com